

COTEK



CR Series User's Manual

CR-20C Remote Control

1.0 Overview

CR-20C is a remote control designed for connecting to SC inverter/charger.

The package is including:

- (1) CR-20C
- (2) 7.5m Cable
- (3) User Manual

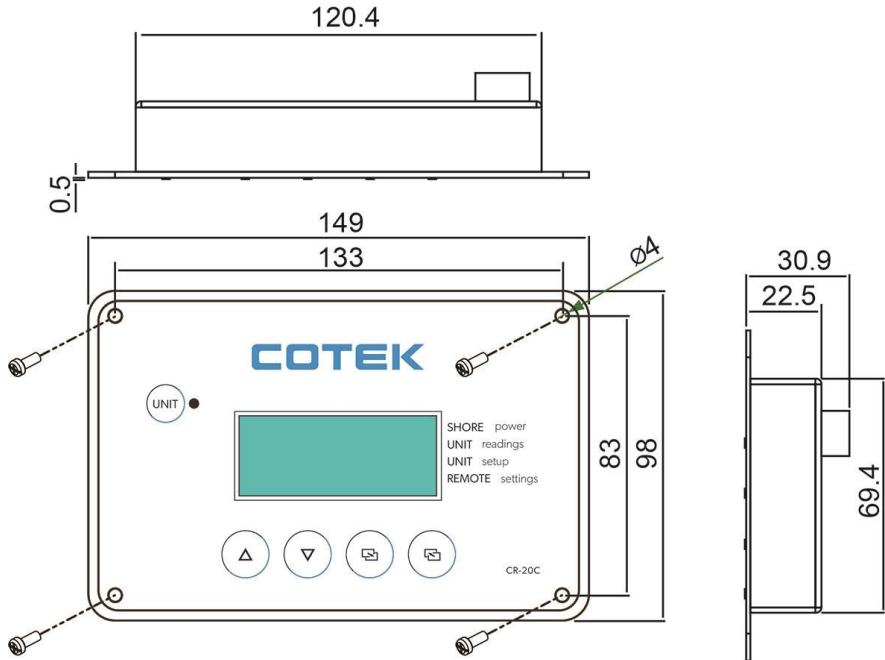

Fig. 1 (Unit: mm)

The CR-20C is equipped with the following features :

1.1 LED Indicator

The LED provides the inverter/charger statuses in a straight forward way.

1.2 LCD Display:

LCD Display - The LCD display is a 16 x 4 line alphanumeric display used for setting up the inverter/charger operation , as well as viewing current status or fault messages.

1.3 ON/OFF Pushbutton

To turn on/off UNIT quickly.

1.4 Buttons

Click buttons allows you to select a menu item or to save a setting, once it is displayed on the LCD screen.



WARNING: Turning the unit OFF does not mean to disconnect the batteries or AC Power Source. Therefore the “AC output load” is still active.



WARNING: Only use the remote control cable supplied, using different cables could cause permanent damage to the SC inverter unit

2.0 Installation

2.1 Installation Guidelines

- Please determine the remote cable route throughout the home or vehicle/boat, both to and from the inverter before connecting any wires.
- Always check for existing electrical, plumbing, or other areas of potential damage before drilling or cutting into walls to mount the remote.
- Make sure all wires have a smooth bend radius and do not become kinked.
- Please ensure the conductors passing through walls, bulkheads, or other structural members are protected. This minimizes insulation damage such as chafing, which can be caused by vibration or constant rubbing when installing this remote in a boat, RV, or truck.

2.2 Installation Overview

The remote is required in order to connect the inverter/charger. Each inverter/charger must be connected directly to the remote using the supplied RJ11 communication cables.

The remote must be located close to the inverter/chargers within 7.5 meters and acts as the system control panel.

2.3 Mounting the Inverter

- Select an appropriate location to install the remote.
- Mount the remote base to the wall using the 4 screws provided.

Please refer to Fig. 1

2.4 Connecting the RJ-11 Cable

Please use RJ-11 cable supplied with remote to connect to inverter/charger.

See below indication.

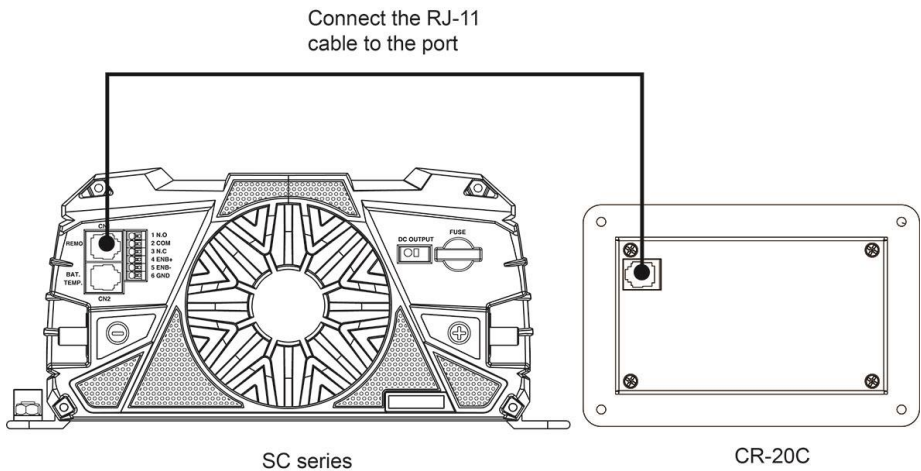

Fig. 2

3.0 Introduction

3.1 Front Panel

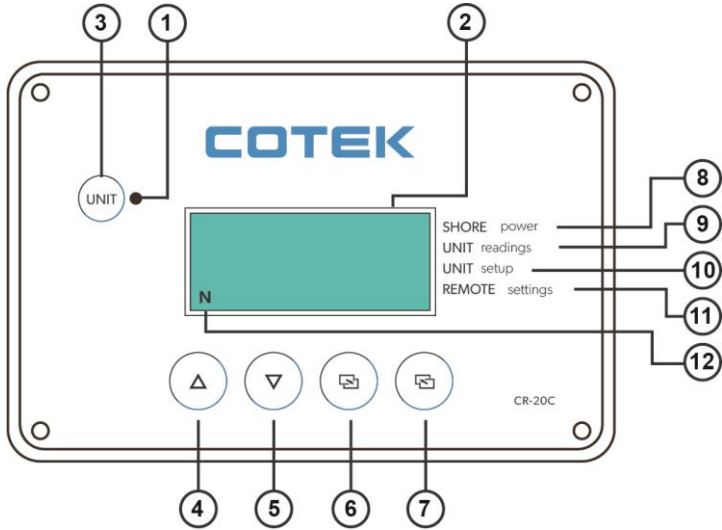

Fig. 3

| | |
|----|---|
| 1 | LED Indicators - There is a LED indicator on the front panel that light solid to indicate the INV ON/OFF. |
| 2 | LCD Display - The LCD display is used for setting up the system operation, as well as viewing current operating status and fault conditions. |
| 3 | UNIT ON/OFF Button - When user pressed it, then CR-20C and unit boot up. |
| 4 | Up Button – move up in the menu tree. |
| 5 | Down Button – move down in the menu tree. |
| 6 | Enter Button – Go to the next page. |
| 7 | Back Button – Go to previous page. |
| 8 | SHORE power - Set Grid input max current.(see 4.1) |
| 9 | UNIT readings - This item show DC ` Temperature ` Grid INPUT and INV OUT, FAULT condition. (see 4.2) |
| 10 | UNIT setup - Setting inverter parameter. (see 4.3) |
| 11 | REMOTE settings - Setting CR-20C parameter. (see 4.4) |
| 12 | Night mode - |

4.0 CR-20C Menu Maps

4.1 SHORE power.

4.2 Select SHORE power and press Enter Button as below frame.

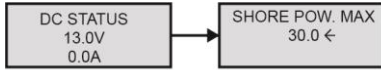

4.3 UNIT readings.

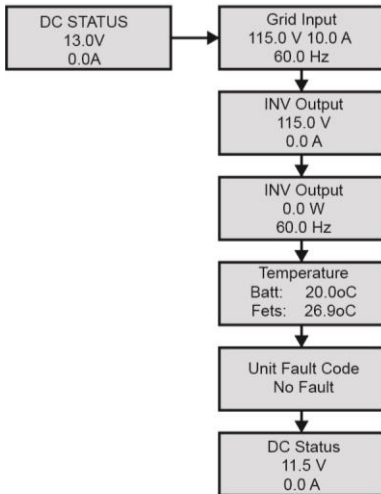

4.4 REMOTE setting.

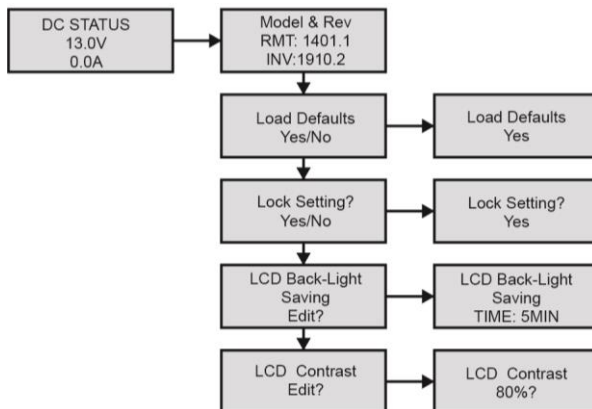

4.5 UNIT setup.

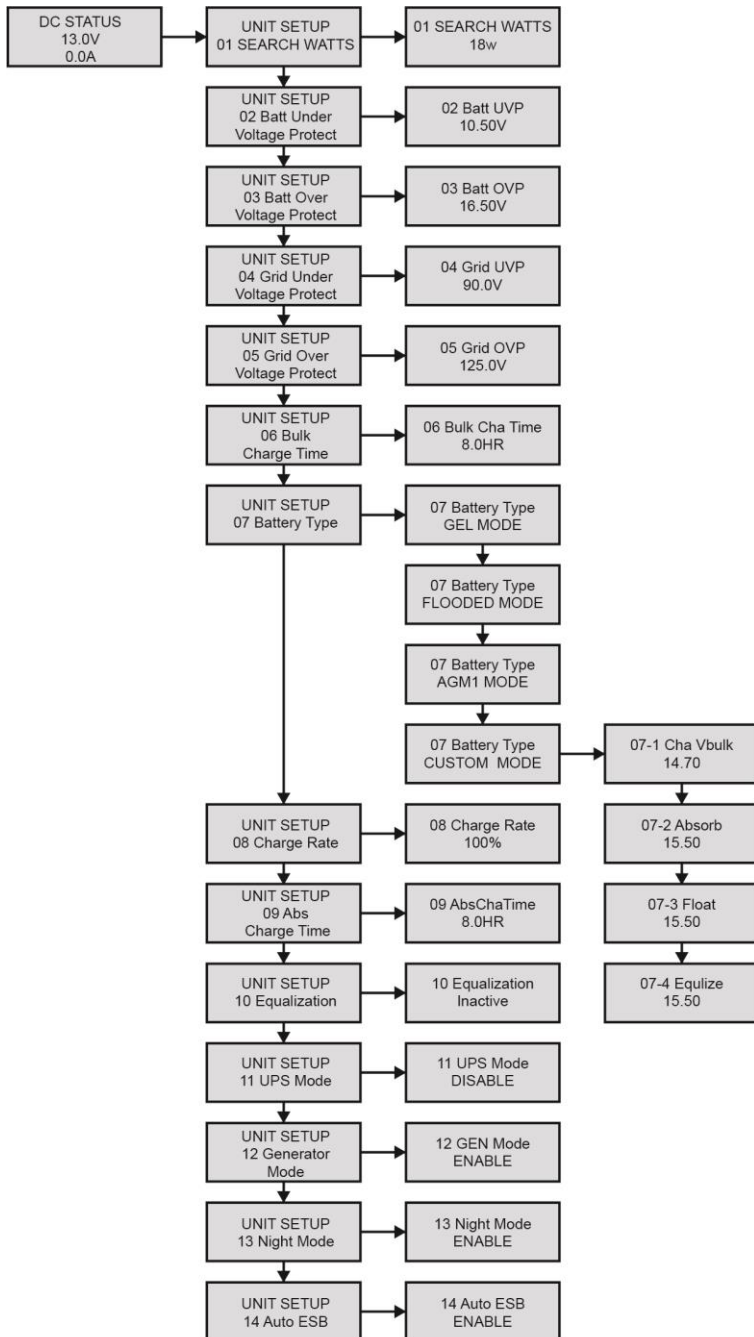

System Status Messages

1.1 UNIT LED indicator

| | UNIT ON/OFF |
|-------------|-------------|
| Solid Green | Normal |
| Solid Red | Error |

No.33, Sec. 2, Renhe Rd., DaxiDist., Taoyuan City 33548, Taiwan

Phone : +886-3-3891999 FAX : +886-3-3802333

[http : // www.cotek.com.tw](http://www.cotek.com.tw)

2020.3_A1