

Features:

- Universal AC input / Full range
- Programmable output Voltage (0% ~ 105%)
- Programmable output Current (0% ~ 105%)
- Built-in active PFC Function
- Forced current sharing at parallel operation
(Refer to pg. 5 for connection diagram)
- Constant current limit
- Selectable +5V / 0.5A or +9V / 0.3A auxiliary output
- Global control via RS232
- Remote setting multiple via RS232, RS485 & I²C
- Power OK signal
- Remote ON / OFF function
- Protection: OVP, OLP, OTP, SCP, Fan failure



MODEL		AEK-3000-150	AEK-3000-200	AEK-3000-250	AEK-3000-300	AEK-3000-400
Output	DC Voltage Rated	150V	200V	250V	300V	400V
	Rated Current	20A	15A	12A	10A	7.5A
	Current Range	0 ~ 20A	0 ~ 15A	0 ~ 12A	0 ~ 10A	0 ~ 7.5A
	Rated Power	3000W				
	Ripple & Noise (Max.)	Note.2 1500mVp-p	2000mVp-p	2500mVp-p	3000mVp-p	4000mVp-p
	Voltage Adj. Range	±5.0% Typical adjustment by potentiometer. (Via V-Adj from PSU front panel)				
	Voltage Tolerance	Note.3 ±2.0% (rated output voltage of single unit)				
	Current Tolerance	±3.0% (rated output current of single unit)				
	Line Regulation	±1.0%				
	Load Regulation	±1.0%				
	Setup, Rise Time	1100ms, 350ms at full load				
Hold Up Time (Typ.)	14ms / 230VAC at full load					
Input	Voltage Range	Note.4 90 ~ 264VAC, 127 ~ 370VDC (Refer to de-rating curve)				
	Frequency Range	47 ~ 63Hz				
	Power Factor (Typ.)	0.95 / 230VAC, 0.98 / 115VAC at full load				
	Efficiency (Max.)	93%				
	AC Current (Max.)	19.7A / 115VAC (2000W), 14.5A / 230VAC (3000W)				
	Inrush Current (Typ.)	33A / 115VAC, 65A / 230VAC				
	Leakage Current	< 3.5mA / 240VAC				
Protection	Over Load	105% rated output power Protection type: Constant current limit				
	Over Voltage	Variable OVP Refer to VCI VS OVP curve.(OVP Tolerance 7%) Protection type: Latch-style (Recovery after reset AC power ON or inhibit)				
	Over Temperature	85 ±5°C detect on NTC, Protection type: Auto recovery after temperature goes down				
Function	Auxiliary Power	Selectable +5V / 0.5A or +9V / 0.3A auxiliary output				
	Remote ON / OFF Control	By external switch				
	Power OK Signal	Open drain signal low when PSU turns on, Max. sink current: 20mA, Max. drain voltage: 40V.				
	Output Voltage Trim	Adjustment of output voltage is between 0 ~ 105% of rated output				
	Output Current Trim	Adjustment of output current is between 0 ~ 105% of rated output				
	Parallel (Current Sharing)	Note.5	Please refer to page 5			
Environment	Working Temp.	-20 ~ +60°C (Refer to de-rating curve)				
	Working Humidity	20 ~ 90% RH non-condensing				
	Storage Temp. & Humidity	-40 ~ +85°C, 10 ~ 95% RH				
	Temp. Coefficient	±0.02% / °C (0 ~ 50°C)				
	Vibration	10 ~ 500Hz, 2G 10min. / 1cycle, period for 60min. each along X, Y, Z axes Compliance to IEC 60068-2-6, IEC 60068-2-64				
Safety & EMC	Safety Standards	Certified EN 62368-1; UL62368-1				
	Withstand Voltage	Note.7	I/P-O/P:3KVAC(4242VDC),I/P-FG:1.5KVAC(2121VDC),O/P-FG:0.5KVAC(707VDC)			
	Isolation Resistance	I/P-O/P, I/P-FG, O/P-FG: 100M Ohms / 500VDC (25°C/70%PH)				
	EMI Conduction Radiation	Certified EN 55032				
	Power Harmonic & Voltage Fluctuation and Flicker	Certified EN 61000-3-2; EN 61000-3-3				
	EMS Immunity	Certified EN 55024; IEC 61000-4-2,3,4,5,6,8,11				
Others	Cooling	Load and temperature control fan				
	Dimension (WxHxD)	170x64x280 mm / 6.69x2.52x11.02 inch				
	Packing	3.3kg; 6pcs / 22.7kg / 2.48CUFT				
Note	<ol style="list-style-type: none"> 1. All parameters NOT specially mentioned are measured at 230VAC input, rated load and 25°C of ambient temperature. 2. Ripple & noise are measured at 20MHz of bandwidth by using a 12" twisted pair-wire terminated with a 0.1uF & 47uF parallel capacitor. 3. Tolerance: includes setup time tolerance, line regulation and load regulation. 4. De-rating may apply in low input voltage. Please check the de-rating curve for more details. 5. In parallel connection only one unit will operate if the total output load is less than 5% of the rated power. 6. The power supply is considered a component which will be installed into a final equipment. The final equipment must be re-confirmed that it still meets EMC directives. 7. This test is done without enclosure: I/P-O/P 4242VDC. If with enclosure: I/P-O/P 2121VDC,I/P-FG:2121VDC, O/P-FG: 707VDC 					

Mechanical Drawings:

Unit:mm / inch

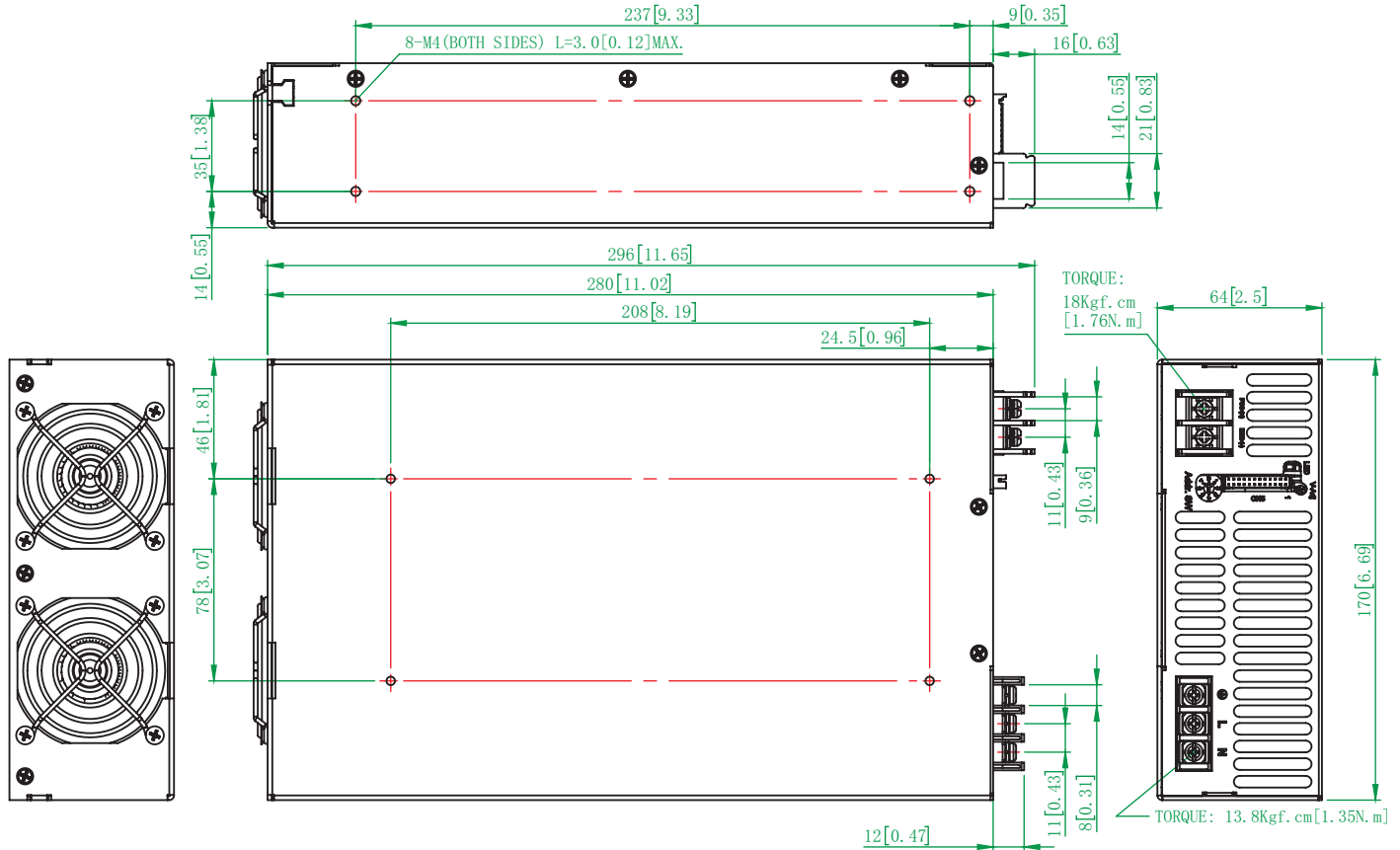

Recommended screw length is measured from the power supply surface

AC Input Terminal Pin No. Assignment

Pin No.	Assignment
L	ACL
N	ACN
⊥	⊥

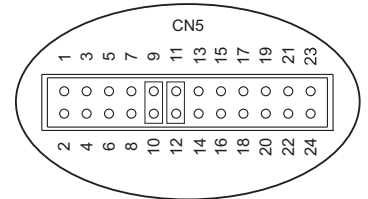

Control pin number assignment (CN5): JST S24B-PHDSS or equivalent

Pin No.	Assignment	Pin No.	Assignment	Pin No.	Assignment	Mating Housing / Contact	
1	NC.	9	EN-	17	AUX	JST PHDR-24VS or equivalent	JST SPHD-002T-P0.5 or equivalent
2	NC.	10	GND	18	GND		
3	NC.	11	EN+	19	SCL		
4	NC.	12	AUX	20	SDA		
5	POK	13	ACI	21	AUX		
6	GND	14	GND	22	GND		
7	PAR	15	VCI	23	RX		
8	VSET	16	GND	24	TX		

CN5 Function Description:

Pin No.	Function	Description	Pin No.	Function	Description
1	NC.		13	ACI	I Program
2	NC.		14	GND	Ground
3	NC.		15	VCI	V Program
4	NC.		16	GND	Ground
5	POK	Power OK	17	AUX	+5V / 0.5A or +9V / 0.3A Auxiliary power
6	GND	Ground	18	GND	Ground
7	PAR	Parallel operation current share	19	SCL	Serial Clock used in the I ² C interface
8	VSET	Aux output setting	20	SDA	Serial Data used in the I ² C interface
9	EN-	Inhibit ON/OFF (-)	21	AUX	+5V / 0.5A or +9V / 0.3A Auxiliary power
10	GND	Ground	22	GND	Ground
11	EN+	Inhibit ON/OFF (+)	23	RX	For RS232 Receiver function
12	AUX	+5V / 0.5A or +9V / 0.3A Auxiliary power	24	TX	For RS232 Transmission function

LED Status:

LED	LED Signal	Status
Solid(Green)		Power OK (Local mode)
Solid(Orange)		Power OK (Remote mode)
Slow Blink(Green)		Power Standby (Local mode)
Slow Blink(Orange)		Power Standby (Remote mode)
Fast Blink(Red)		Over Voltage Protection (OVP)
Solid(Red)		Over Load Protection (OLP)
Slow Blink(Red)		Over Temperature Protection (OTP)
Intermittent Blink(Red)		Fan Failure
Interface Blink(Red)		Power Failure

*Local mode : Use ACI/VCI control output current and voltage.
Remote mode : Use RS-232 or I²C command control output current and voltage.

De-rating Curve:

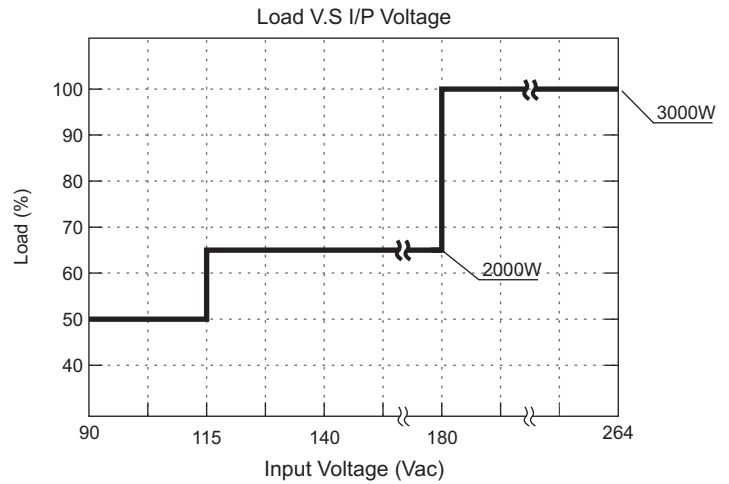
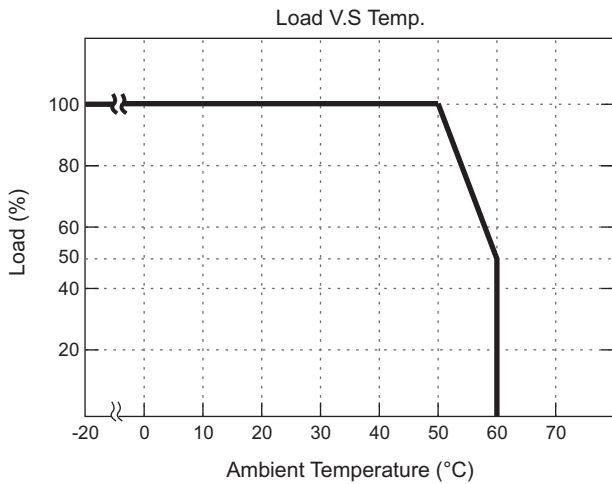

CMD VS Output Curve:

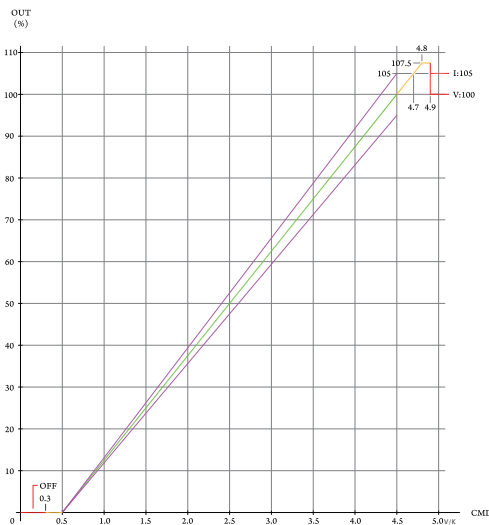

VCI VS OVP Curve:

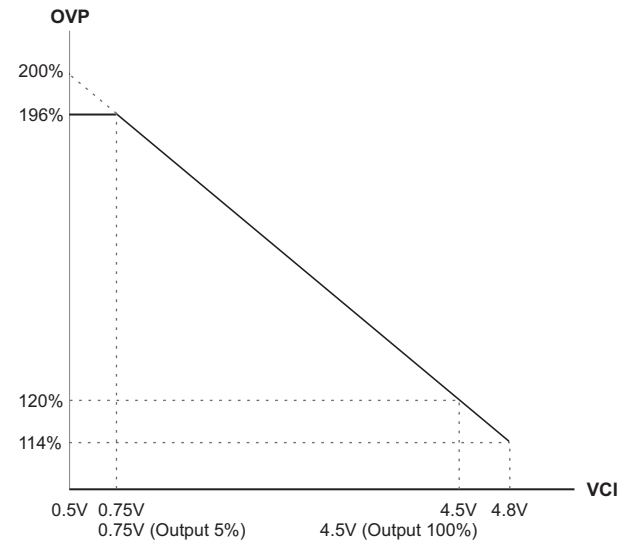

To ensure the power supply output voltage and current could be accurately adjusted, please make sure to adjust the output voltage and current > 10% vs. the rated voltage and current. (e.g. for a 300V unit, please adjust the DC output voltage above 30V to ensure accuracy; same applies to the output current)

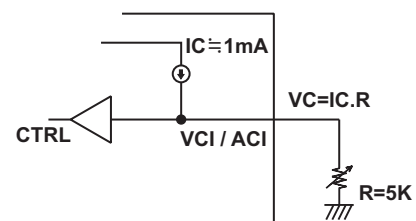
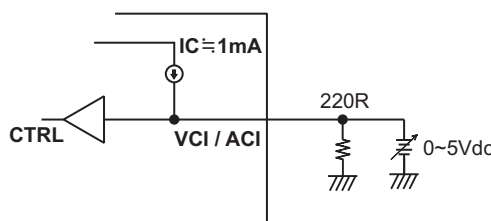
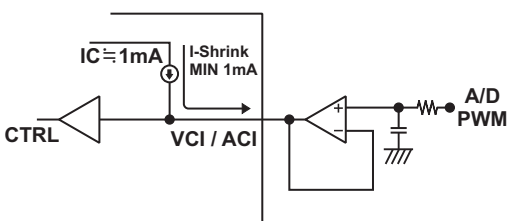
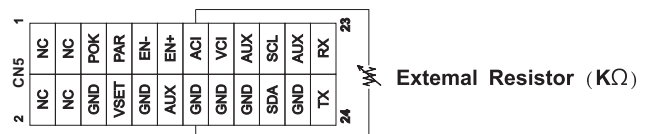
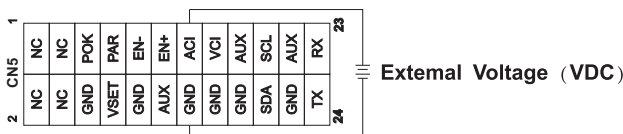

Remote ON/OFF:

(A) Default Setting

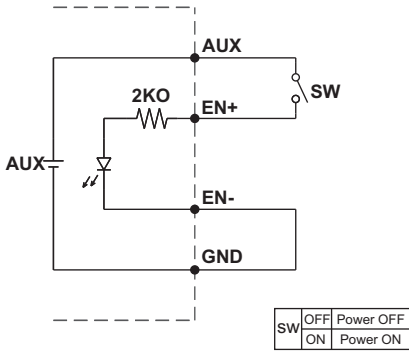

(A) Using internal 5V auxiliary source

(B)

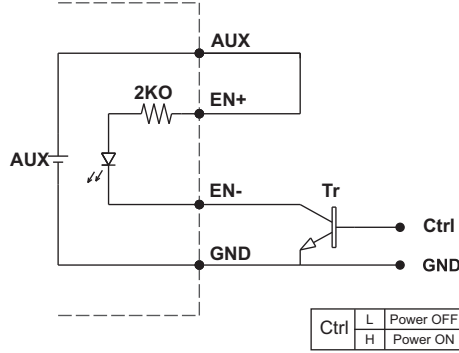

(B) ON / OFF Control by NPN transistor

(C)

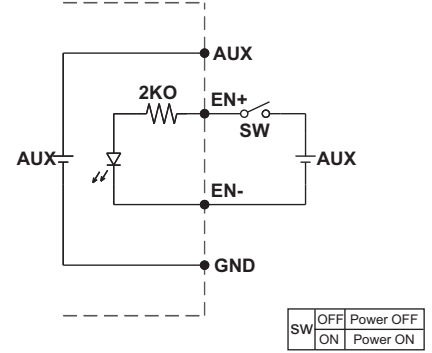

(C) Using external voltage source

GND shown in above diagram is referring to the GND of CN2, not the Grounding from main power(NEG-).

Power OK Signal & Auxiliary Power Setting:

*The grounding of "AUX" power and P.OK signal should be connected to "GND" port. If "VO-" is connected as Grounding, make sure to short the GND and VO- ports.

Open drain signal low when PSU turns on, Max. P.OK sink current: 20mA, Max. drain voltage: 40V.

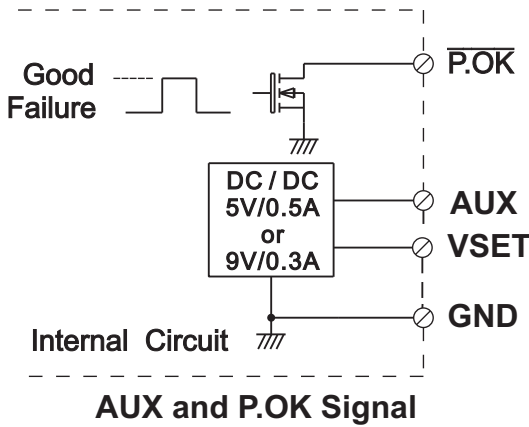

AUX and P.OK Signal

VSET	Open(Default Setting)	5V
	Short To GND	9V

GND shown in above diagram is referring to the GND of CN2, not the Grounding from main power(NEG-).

*Place an additional capacitor to have a better performance of auxiliary power operation.

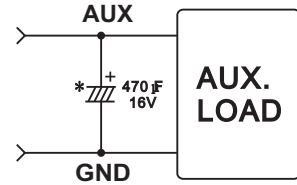

Do NOT exceed 5V/0.5A or 9V/0.3A

1. Current Sharing

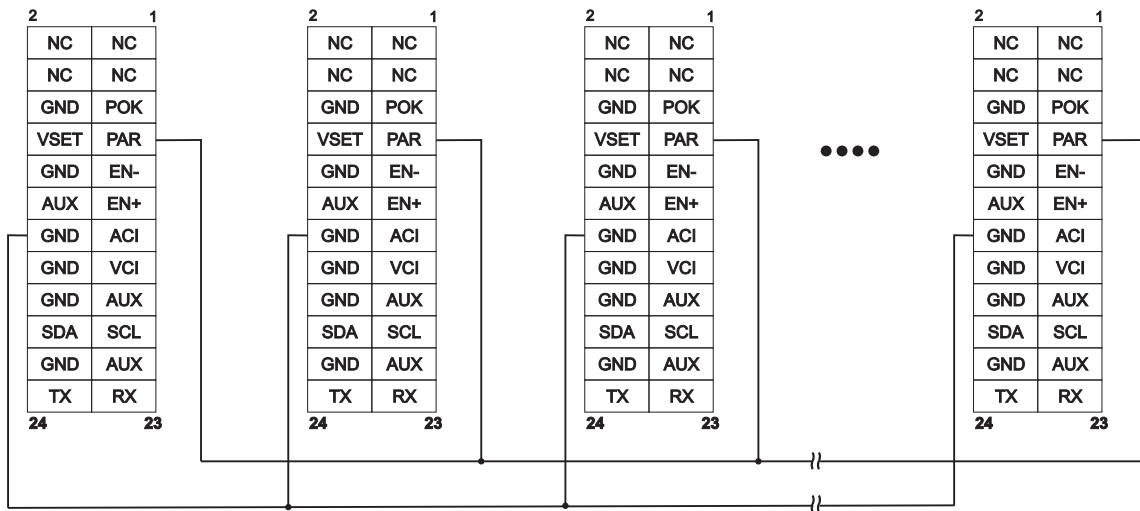
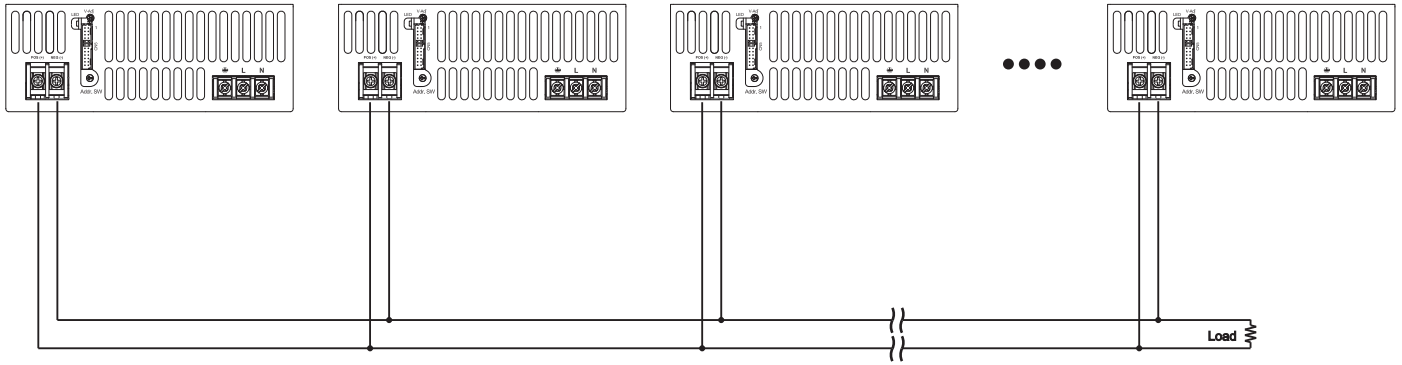

Please connect PAR pins together for current sharing function
 For Series connection, make sure to isolate CN2 control signals

Installation Instruction:

1. Mounting Directions

1-1 Recommended standard mounting methods:

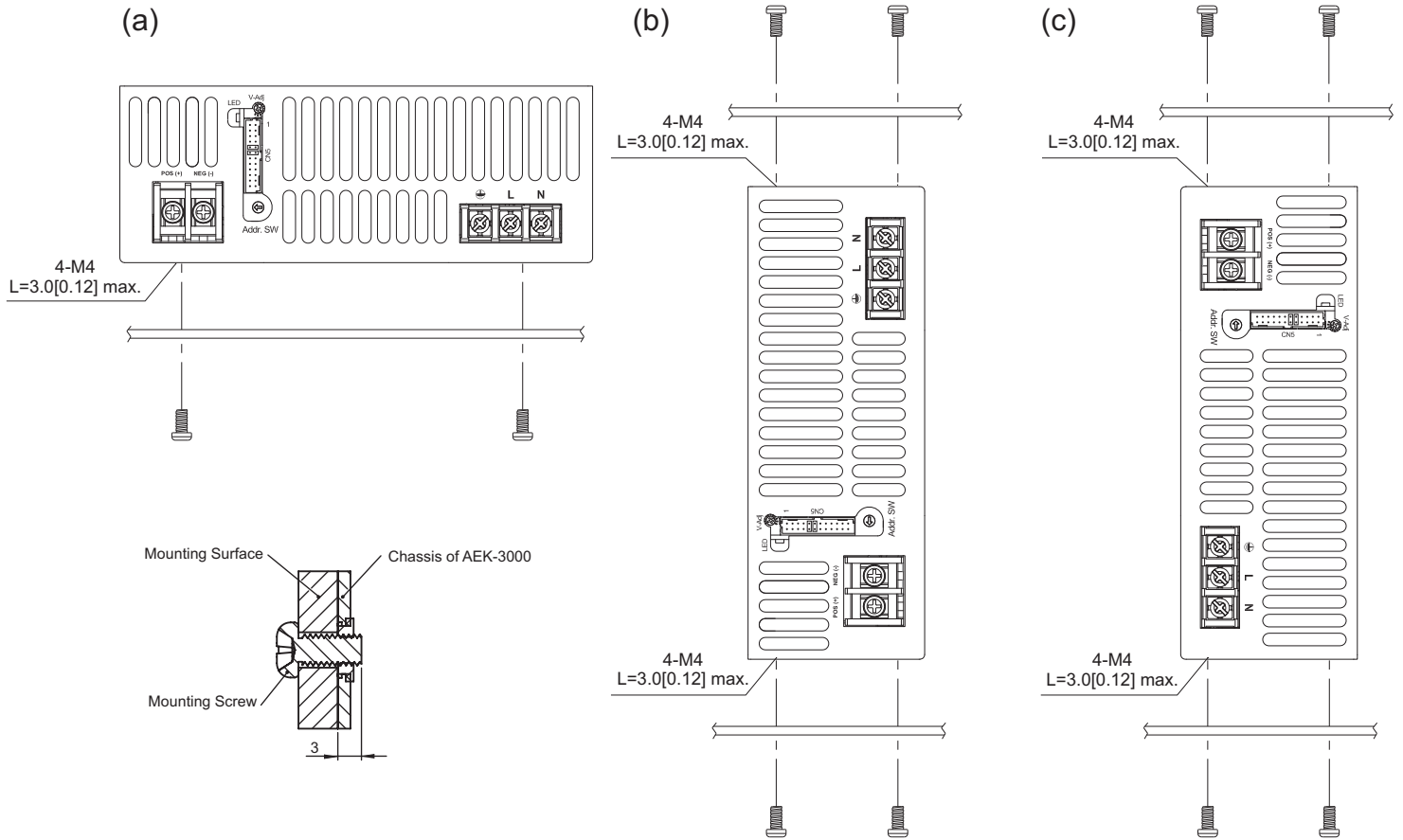

Recommended screw length is measured from the power supply surface

2. Mounting Method

2-1 There are ventilating holes on the front and back side panels, do not obstruct; allow 50mm at least for air flow.

2-2 The Maximum allowable penetration of screw is 3mm. Incomplete threading should not be penetrated.

2-3 Recommended the torque of mounting screw:
M4 screw: $1.27\text{N} \cdot \text{m}$ ($13.0\text{kgf} \cdot \text{cm}$)

